

## Optocoupler with Phototransistor Output

### Description

The TCDT1110(G) consist of a phototransistor optically coupled to a gallium arsenide infrared emitting diode in a 6 lead plastic dual inline packages.

The elements are mounted on one leadframe in coplanar technique, providing a fixed distance between input and output for highest safety requirements.

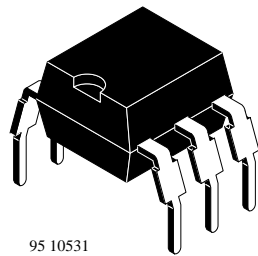

95 10531

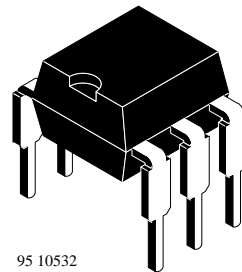

95 10532

### Applications

Circuits for safe protective separation against electrical shock according to safety class II. (reinforced isolation):

- for application class I – IV at main voltages < 300 V;
- for class I – III at main voltage < 600 V according to VDE 0884, table 2, suitable for:

**Switch mode power supplies, computer peripheral interface, microprocessor system interface, line receiver.**



**0884**

These couplers perform safety functions according to following equipment standards:

- **VDE 0884**  
Optocoupler providing protective separation
- **VDE 0804**  
Telecommunication apparatus and data processing
- **VDE 0805/IEC 950/EN 60950**  
Office machines (applied for reinforced isolation for main voltage  $\leq 400 V_{RMS}$ )
- **VDE 0860/IEC 65**  
Safety for mains operated electronic and related apparatus for household

## Feature

According to VDE 0884

- Rated impulse voltage (transient overvoltage)  
 $V_{IOTM} = 6 \text{ kV peak}$
- Isolation test voltage (partial discharge test voltage)  
 $V_{pd} = 1.6 \text{ kV}$
- Rated isolation voltage (RMS includes DC)  
 $V_{IOWM} = 600 \text{ V}_{RMS}$  (848 V peak)
- Rated recurring peak voltage (repetitive)  
 $V_{IORM} = 600 \text{ V}_{RMS}$
- Creeping current resistance according to VDE 0303/IEC 112  
Comparative Tracking Index: **CTI = 275**
- Thickness through insulation  $\geq 0.75 \text{ mm}$
- Further approvals:  
BS 415, BS 7002, SETI: IEC 950,  
UL 1577: File No: E 76222
- Isolation materials according to UL94-VO
- Pollution degree 2 (DIN/VDE 0110 resp. IEC 664)
- Climatic classification  
55/100/21 (IEC 68 part 1)
- Special construction:  
therefore extra low coupling capacity  
typical 0.3 pF, high **Common Mode Rejection**
- Low temperature coefficient of CTR
- Base not connected

## Pin Connection

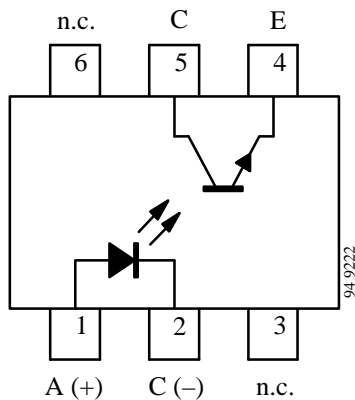

## Absolute Maximum Ratings

### Input (Emitter)

Parameters	Test Conditions	Symbol	Value	Unit
Reserve voltage		$V_R$	6	V
Forward current		$I_F$	60	mA
Forward surge current	$t_p/T \leq 10 \mu s$	$I_{FSM}$	3	A
Power dissipation	$T_{amb} \leq 25^\circ C$	$P_{tot}$	100	mW
Junction temperature		$T_j$	125	$^\circ C$

### Output (Detector)

Parameters	Test Conditions	Symbol	Value	Unit
Collector emitter voltage		$V_{CEO}$	70	V
Emitter collector voltage		$V_{ECO}$	7	V
Collector current		$I_C$	50	mA
Collector peak current	$t_p/T = 0.5, t_p \leq 10 ms$	$I_{CM}$	100	mA
Power dissipation	$T_{amb} \leq 25^\circ C$	$P_{tot}$	150	mW
Junction temperature		$T_j$	125	$^\circ C$

### Coupler

Parameters	Test Conditions	Symbol	Value	Unit
AC isolation test voltage (RMS)		$V_{IO}$	3.75	kV
Total power dissipation	$T_{amb} \leq 25^\circ C$	$P_{tot}$	250	mW
Ambient temperature range		$T_{amb}$	-55 to +100	$^\circ C$
Storage temperature range		$T_{stg}$	-55 to +125	$^\circ C$
Soldering temperature	2 mm from case, $t \leq 10 s$	$T_{sd}$	260	$^\circ C$

## Maximum Safety Ratings <sup>1)</sup> (according to VDE 0884)

### Input (Emitter)

Parameters	Test Conditions	Symbol	Value	Unit
Forward current		$I_{si}$	130	mA

### Output (Detector)

Parameters	Test Conditions	Symbol	Value	Unit
Power dissipation	$T_{amb} \leq 25^\circ C$	$P_{si}$	265	mW

### Coupler

Parameters	Test Conditions	Symbol	Value	Unit
Rated impulse voltage		$V_{IOTM}$	6	kV
Safety temperature		$T_{si}$	150	$^\circ C$

<sup>1)</sup> This device is used for protective separation against electrical shock only within the maximum safety ratings. This must be ensured by protective circuits in the applications.

## Derating Diagram

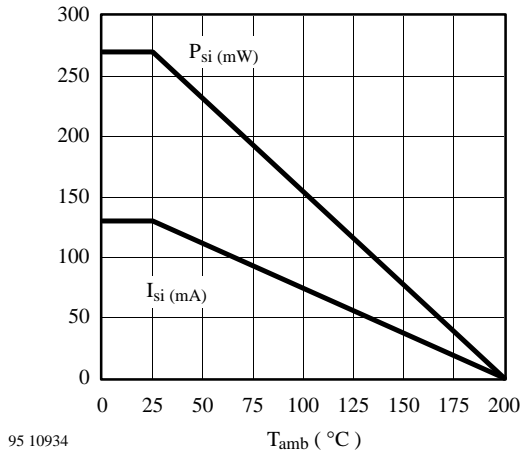

## Electrical Characteristics

$T_{amb} = 25^\circ\text{C}$

### Input (Emitter)

Parameters	Test Conditions	Symbol	Min.	Typ.	Max.	Unit
Forward voltage	$I_F = 50\text{ mA}$	$V_F$		1.2	1.5	V
Breakdown voltage	$I_R = 100\text{ }\mu\text{A}$	$V_{(BR)}$	6			V
Junction capacitance	$V_R = 0, f = 1\text{ MHz}$	$C_j$		50		pF

### Output (Detector)

Parameters	Test Conditions	Symbol	Min.	Typ.	Max.	Unit
Collector emitter breakdown voltage	$I_C = 1\text{ mA}$	$V_{(BR)CEO}$	70			V
Emitter collector breakdown voltage	$I_E = 100\text{ }\mu\text{A}$	$V_{(BR)ECO}$	7			V
Collector cut-off current	$V_{CE} = 30\text{ V}, I_F = 0$	$I_{CEO}$			150	nA

### Coupler

Parameters	Test Conditions	Symbol	Min.	Typ.	Max.	Unit
AC isolation voltage test (RMS)	$f = 50\text{ Hz}, t = 2\text{ s}$	$V_{IO}^{(2)}$	3.75			kV
$I_C/I_F$	$V_{CE} = 20\text{ V}, I_F = 10\text{ mA}$	CTR	1			
Collector emitter saturation voltage	$I_F = 10\text{ mA}, I_C = 0.5\text{ mA}$	$V_{CEsat}$			0.3	V
Cut-off frequency	$V_{CE} = 5\text{ V}, I_F = 10\text{ mA}, R_L = 1\text{ }\Omega$	$f_c$		110		kHz
Coupling capacitance	$f = 1\text{ MHz}$	$C_k$		0.3		pF

<sup>2)</sup> related to standard climate 23/50 DIN 50014

## Switching Characteristics

$V_S = 10\text{ V}$

Type	$R_L = 100\ \Omega$ , see figure 1							$R_L = 1\text{ k}\Omega$ , see figure 2		
	$t_d[\mu\text{s}]$	$t_r[\mu\text{s}]$	$t_{on}[\mu\text{s}]$	$t_s[\mu\text{s}]$	$t_f[\mu\text{s}]$	$t_{off}[\mu\text{s}]$	$I_C[\text{mA}]$	$t_{on}[\mu\text{s}]$	$t_{off}[\mu\text{s}]$	$I_F[\text{mA}]$
			15			15	2	9	18	10

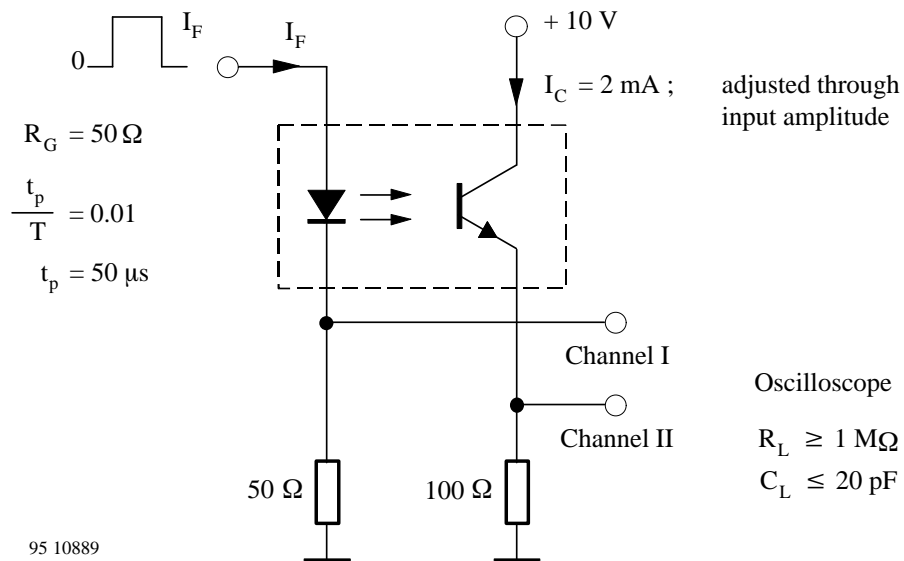

Figure 1. Test circuit, non-saturated operation

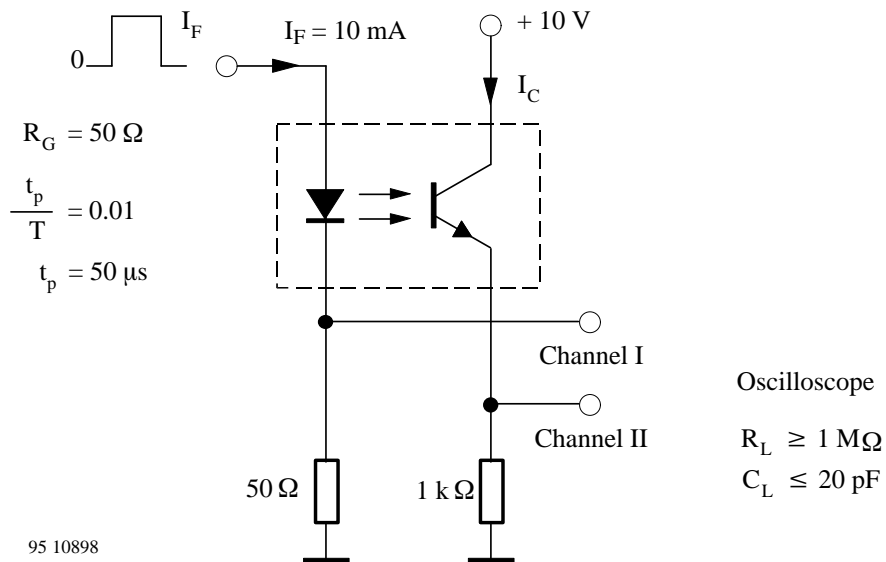

Figure 2. Test circuit, saturated operation

## Insulation Rated Parameters (according to VDE 0884)

Parameters		Test Conditions	Symbol	Min.	Typ.	Max.	Unit
Partial discharge test voltage	Routine test	100%, $t_{test} = 1$ s	$V_{pd}$	1.6			kV
	Lot test (sample test)	$t_{Tr} = 10$ s, $t_{test} = 60$ s see figure 2	$V_{IOTM}$	6			kV
			$V_{pd}$	1.3			kV
Insulation resistance		$V_{IO} = 500$ V	$R_{IO}$	$10^{12}$			$\Omega$
		$V_{IO} = 500$ V, $T_{amb} = 100^{\circ}C$	$R_{IO}$	$10^{11}$			$\Omega$
		$V_{IO} = 500$ V, $T_{amb} = 200^{\circ}C$ (only construction test)	$R_{IO}$	$10^9$			$\Omega$

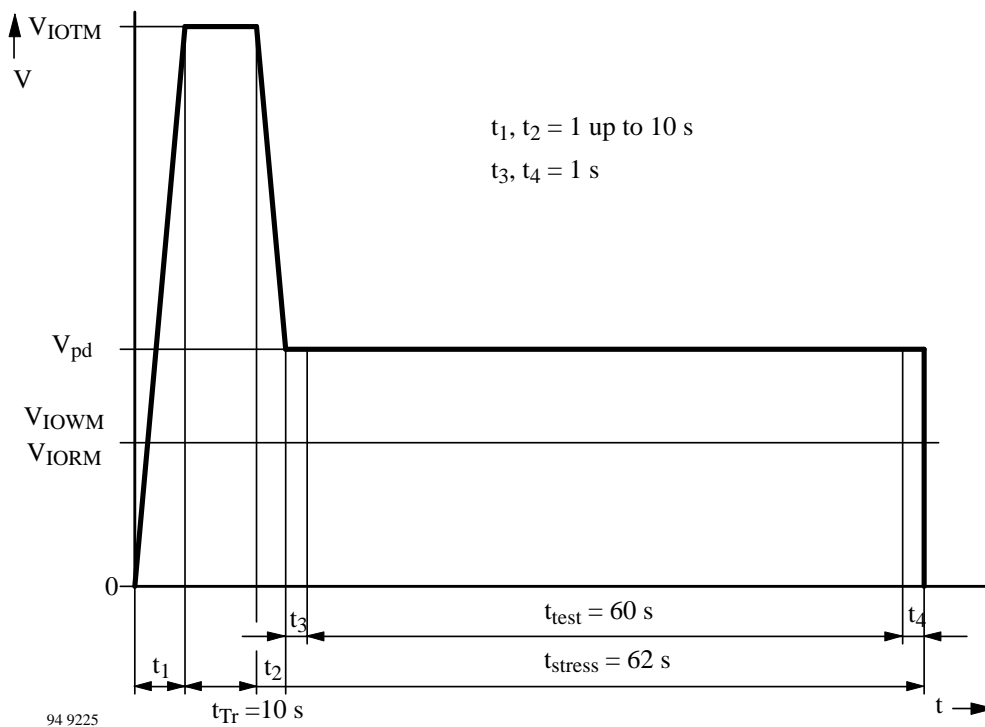
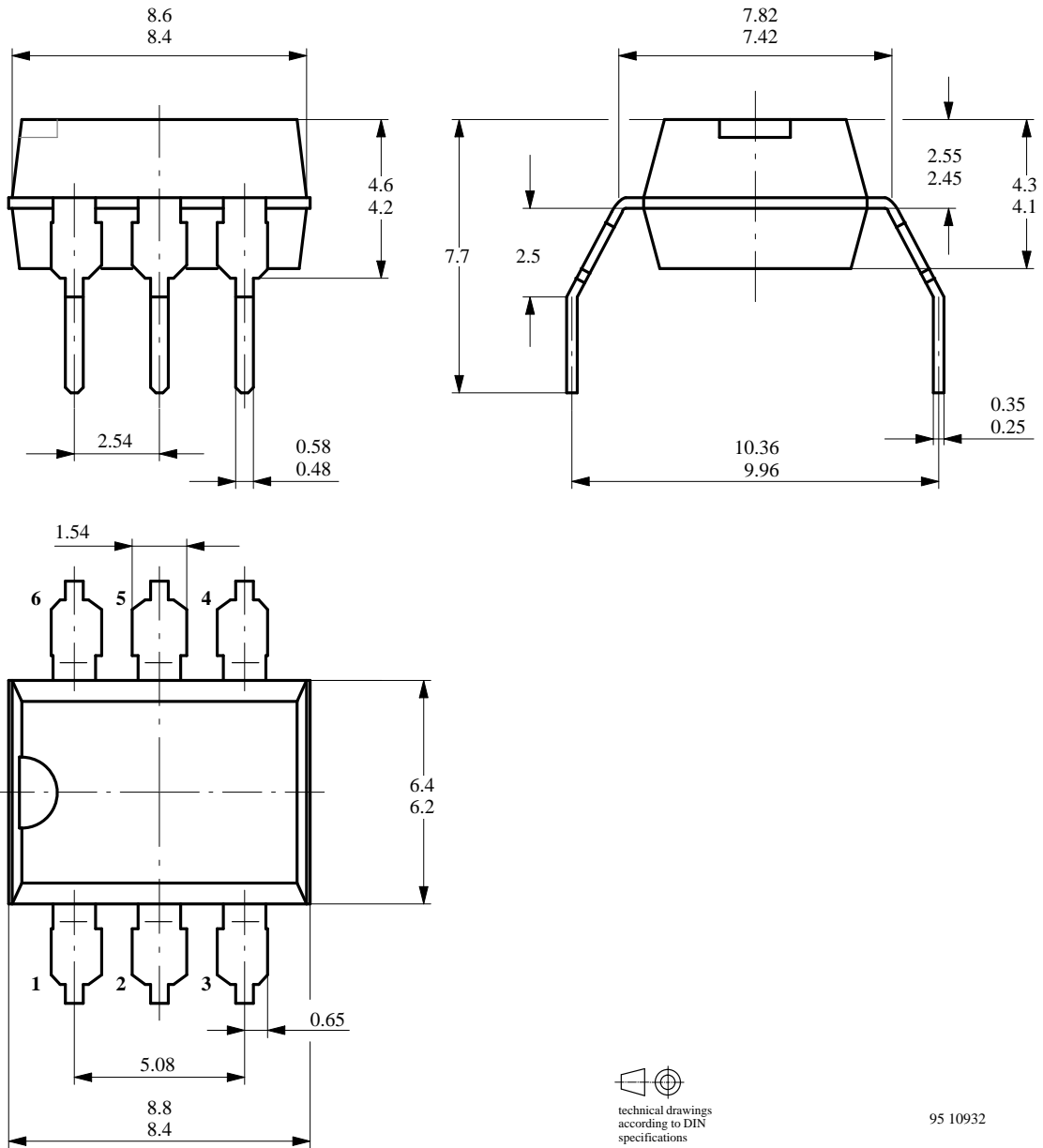

Figure 3. Test pulse diagram for sample test according DIN VDE 0884

## Dimensions in mm

Leadform 10.16. mm (G-type)





# TCDT1110(G)

# TEMIC

TELEFUNKEN Semiconductors

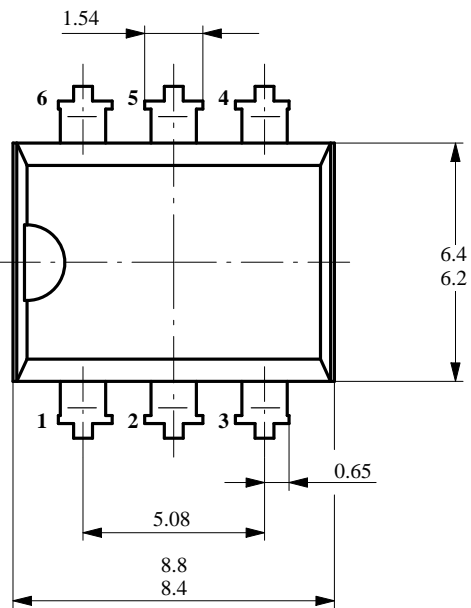
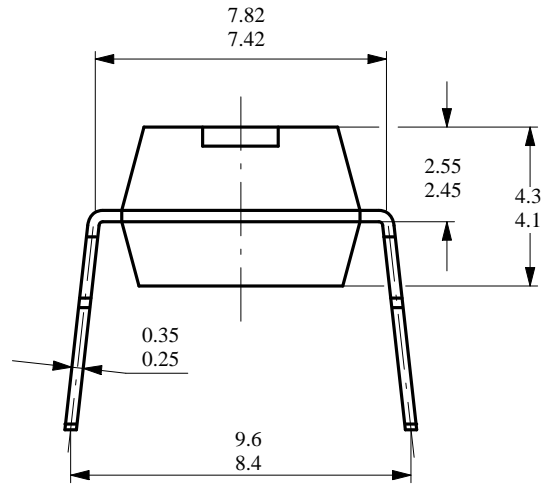
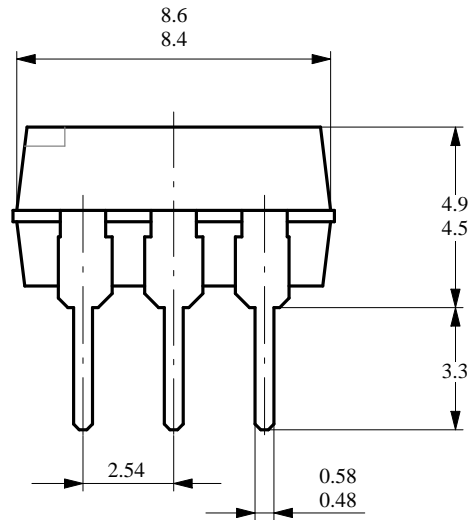
## Dimensions in mm



  
technical drawings  
according to DIN  
specifications

95 10931



## Ozone Depleting Substances Policy Statement

It is the policy of **TEMIC TELEFUNKEN microelectronic GmbH** to

1. Meet all present and future national and international statutory requirements.
2. Regularly and continuously improve the performance of our products, processes, distribution and operating systems with respect to their impact on the health and safety of our employees and the public, as well as their impact on the environment.

It is particular concern to control or eliminate releases of those substances into the atmosphere which are known as ozone depleting substances (ODSs).

The Montreal Protocol (1987) and its London Amendments (1990) intend to severely restrict the use of ODSs and forbid their use within the next ten years. Various national and international initiatives are pressing for an earlier ban on these substances.

**TEMIC TELEFUNKEN microelectronic GmbH** semiconductor division has been able to use its policy of continuous improvements to eliminate the use of ODSs listed in the following documents.

1. Annex A, B and list of transitional substances of the Montreal Protocol and the London Amendments respectively
2. Class I and II ozone depleting substances in the Clean Air Act Amendments of 1990 by the Environmental Protection Agency (EPA) in the USA
3. Council Decision 88/540/EEC and 91/690/EEC Annex A, B and C (transitional substances) respectively.

**TEMIC** can certify that our semiconductors are not manufactured with ozone depleting substances and do not contain such substances.

**We reserve the right to make changes to improve technical design and may do so without further notice.**

Parameters can vary in different applications. All operating parameters must be validated for each customer application by the customer. Should the buyer use TEMIC products for any unintended or unauthorized application, the buyer shall indemnify TEMIC against all claims, costs, damages, and expenses, arising out of, directly or indirectly, any claim of personal damage, injury or death associated with such unintended or unauthorized use.

TEMIC TELEFUNKEN microelectronic GmbH, P.O.B. 3535, D-74025 Heilbronn, Germany  
Telephone: 49 (0)7131 67 2831, Fax number: 49 (0)7131 67 2423